

**Refrigeration Equipment
Sandwich/Salad Preparation
Table, 6cu.ft - Stainless Steel**

ITEM # _____

MODEL # _____

NAME # _____

SIS # _____

AIA # _____



738066 (KCST278-HC)

Sandwich/salad preparation table, 6 cu.ft, +33/+41°F, stainless steel

Short Form Specification

Item No. _____

Constructed entirely in stainless steel. Built-in refrigeration unit and an insulated lid to maintain food freshness. Fin & Tube Condenser improves performance in high-temperature environments. Automatic Defrost Cooling System to provide worry-free performances. Full-depth cutting board of 79x27.40x10.50 in. Digital control panel, Vinyl-Coated Steel adjustable shelves, removable door gaskets and self-closing doors with 90-degree stay-open feature. Temperature range: +33/+41°F.

R290 gas in the refrigeration circuit.
ETL Safety and Sanitation certifications.
3/5 Years warranty.

Main Features

- Fin & Tube Condenser improves performance in high-temperature environments.
- Automatic Defrost Cooling System provides worry-free performance.
- 1/3 HP Compressor.
- Vinyl-Coated Steel adjustable dividers to customize bottle storage effortlessly.
- Hydrocarbon refrigerant gas R290 for the lowest environmental impact (GWP=3) - CFC and HCFC free.

Construction

- Stainless steel exterior and interior, durable and easy to clean for daily commercial use.
- External Electronic Digital Temperature Control for easy setting and monitoring.
- Removable door gaskets.
- Holds (6) 1/6 & (2) 1/9 pans.
- Self-closing door with 90-degree stay-open feature.
- Heavy duty casters.
- Insulated lid maintains food freshness.
- Preparation area designed for workstation convenience and self-food handling, also thanks to the full-depth cutting board.

APPROVAL: _____

Front

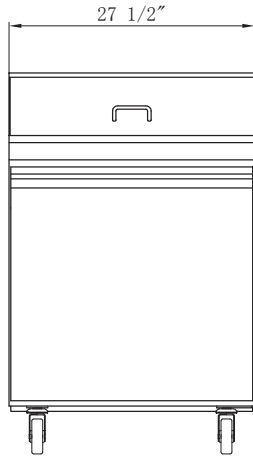

Side

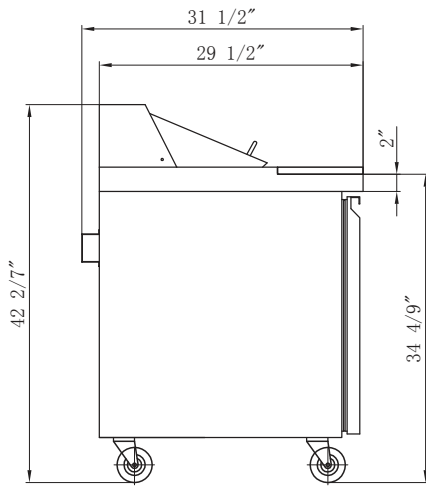

EI = Electrical connection

Top

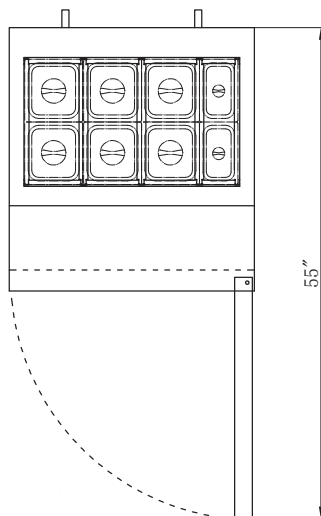

Electric

Supply voltage:

738066 (KCST27.8-HC) 115 V/1 ph/60 Hz

Electrical power, max:

0.6 kW

Plug type:

USA NEMA 1-15P

Capacity:

Gross capacity: 7.9 cu.feet

Key Information:

External dimensions, Width: 27 1/2" (698.5 mm)
External dimensions, Depth: 29 1/2" (749.3 mm)
External dimensions, Height: 42 5/16" (1074.06 mm)
Number and type of doors: 1 Full
Number and type of grids (included): -1
Type of external material: Stainless Steel
Type of internal material: 304 AISI
Warranty: 3 / 5 years

Refrigeration Data

Compressor power: 1/5 hp
Refrigerant type: R290
Operating temperature min.: 33 °F
Operating temperature max.: 41 °F
Condenser type: Fin & tube
Defrost type: Auto Defrost